

# AEROSAFE

SMOKE CURTAINS

HSC-03



Intertek

Applus<sup>+</sup>



## INDEX

Introduction .....	04
Automatic Smoke Curtains .....	05
Components .....	06 - 07
Roller Assembly .....	08
Electronic Control Systems .....	09 -10
Aerosafe Control Systems Operation .....	11
Main Features & Smoke Curtains Specification .....	12
Applications .....	13
Draft Smoke Curtains & Advantages .....	14

## INTRODUCTION

Smoke curtains are a great way to control smoke. They're simple to install in existing structures and integrate with existing detection and response systems.

According to the National Fire Protection Association (NFPA), smoke inhalation is more likely than the fire itself to be the cause of death (i.e., burns). Smoke inhalation was estimated to be the cause of 40 percent to 50 percent of fatalities.

In order to safeguard building inhabitants from injury during a fire, you must protect them from both smoke inhalation and actual flames.

Smoke curtains, unlike other smoke control equipment like exterior exhaust vents, provide a physical barrier against smoke. When deployed, the smoke curtain will deploy vertically from its housing located in the ceiling. These curtains can seal off doorways and elevators, and they can even form an independent perimeter around staircases and atriums where no walls are present.

There are several styles of smoke curtains, making them an excellent alternative for building owners who want to effectively manage smoke.

## AUTOMATIC SMOKE CURTAINS

**Aerosafe Automatic Smoke Curtains** contribute in smoke management of a building by channelising the movement of smoke to smoke extraction points or by creating reservoirs to slow down the spreading of smoke.

Curtains remain virtually invisible in their retracted position within the compacted head-box.

When signalled by a local detector or fire alarm system, the curtain descends to the operational level using the gravity fail safe system.

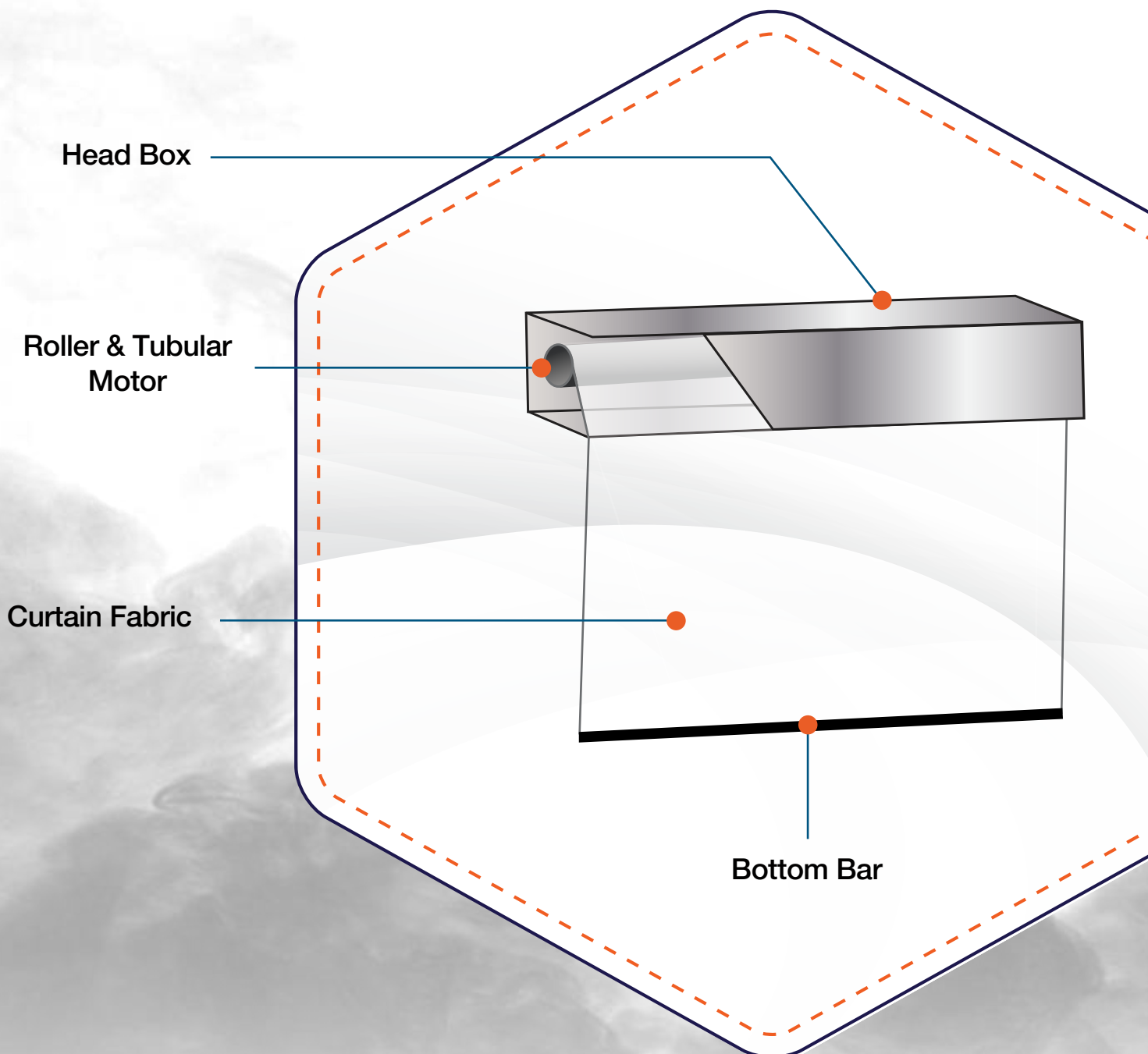

## COMPONENTS

### Head Box

The steel head box houses the roller, fabric and motor within the casing creating a small compact package that is above the ceiling and not visible.

The curtain head box is manufactured from 1.2 mm galvanised steel, the enclosure is rated at the same temperature as the curtain fabric. Removable cover plates are incorporated to allow access to the curtain rollers. Standard head box sizes are 170 mm x 170 mm for single rollers (maximum width 5.0 m) and 210 mm x

375 mm for multiple rollers (over 5.0 m wide). Larger head

boxes may be required where the curtain drop is in excess of 3 m.

Over/under configuration for long runs of overlapping curtains. It can be powder coated to any RAL color.



### Aerosafe Roller

Aerosafe Roller drives a 76 mm steel roller tube to retract and deploy the fabric from normal position in the head box to its operational position. Factory assembled and fitted inside roller barrel.

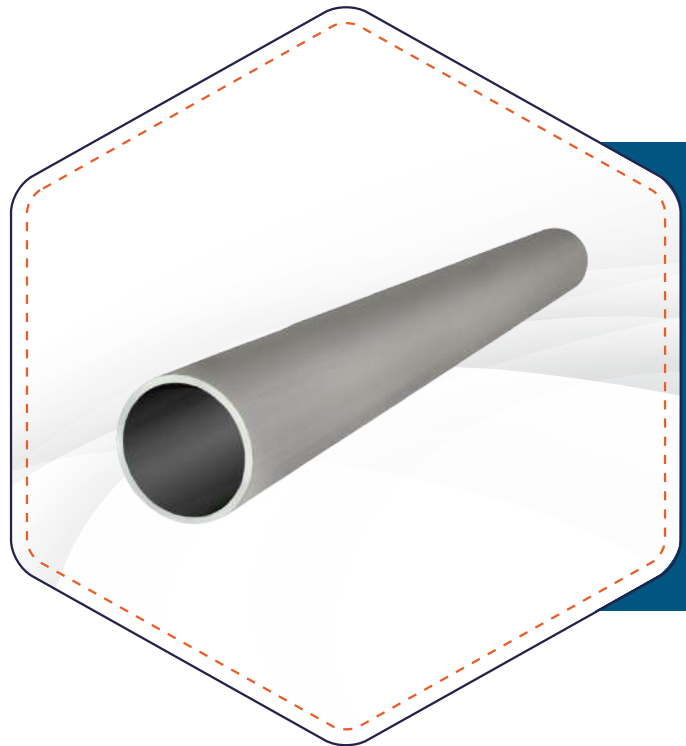

## Curtain Fabric

An important component of a Smoke Curtain system is the fabric. The fabric is designed to withstand heat and fire, including temperatures up to 600 °C.

When tested in accordance with BS EN 12101-1 using the Aerosafe fabric, the complete assembly achieved an integrity performance of up to 180 minutes. The fabric is special fiberglass fiber coated with a fire retardant polyurethane in both side and tailored according to required dimension.

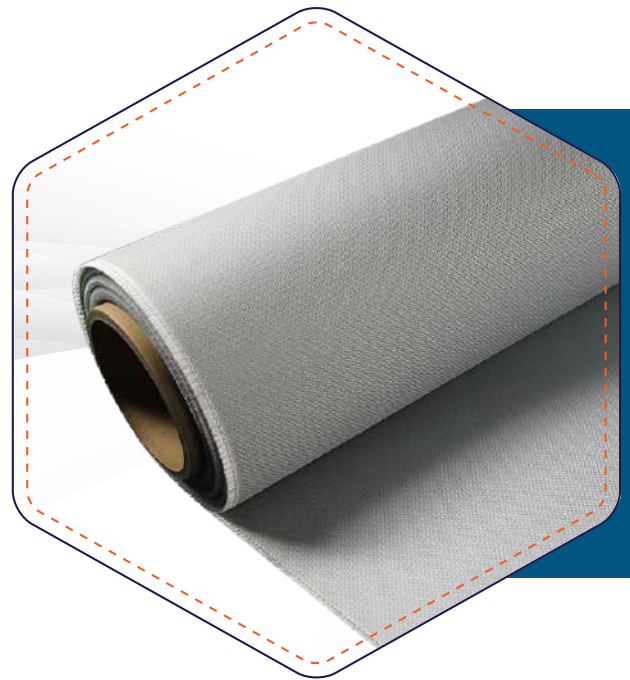

## Fabric Properties Table

Properties	
Integrity duration	180 minutes
Thickness	0.41 ±0.03 mm
Coated side	On both sides
Coating	Fire retardant polyurethane
Thread	Stainless steel
Standard color	Gray

## Bottom Bar

The Aerosafe Smoke Curtain bottom bar provides weight and stability to the system ensuring a gravity fail safe deployment and to stabilize the curtain during descent.

A minimum of 4 kg weight per standard motor is required to ensure that the curtain deploys properly.

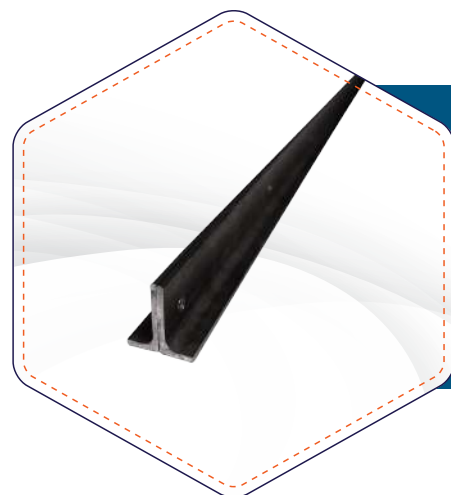

## ROLLER ASSEMBLY

### Single Roller

Single Roller Assembly can accommodate up to 5 m width curtain.

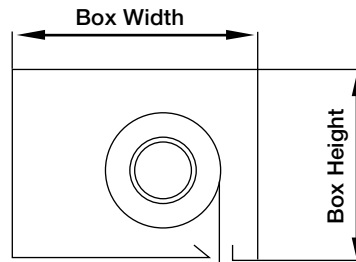

Curtain Drop	Single Roller Box	
	Width (mm)	Height (mm)
Upto 3 m	170	170
3 m to 6 m	210	210

### Multiple Roller

To achieve a virtually unlimited width without the need for intermediate guide rails, Multiple Rollers are arranged in an 'over-under' arrangement and neatly encased within the head box.

Multiple Rollers utilize the use of a 300 mm fabric overlap arrangement which removes the need for intermediate side guides and minimizes the potential for roller bounce.

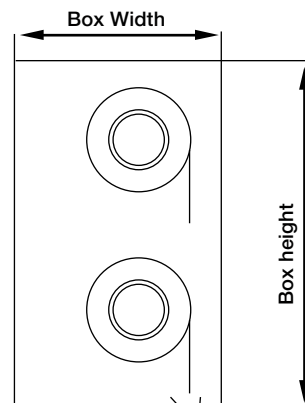

Curtain Drop	Multiple Roller Box	
	Width (mm)	Height (mm)
Upto 3 m	170	300
3 m to 6 m	210	375

## ELECTRONIC CONTROL SYSTEMS

### Aerosafe Automatic Electronic Control Systems

The system must provide for the fail safe movement of the curtain to the operational position on total loss of primary and auxiliary power. Under normal operating conditions the curtains would be held in the retracted position via the motors operating at low voltage. Upon activation of the fire alarm, the control panel will remove the supply voltage and the curtain will descend under the power of gravity in a controlled manner. A dynamic braking system housed in the motor control circuit controls the speed of descent of the curtain, this is electronically synchronised on overlapping curtains with a common bottom bar.

To retract the curtain, the control panel supplies 24v to the motor control circuits and the motors drive the curtains to the upper position. As the bottom bar or stopping bar hits the curtain head box, a current limiting circuit steps back the voltage and current, and holds the bottom bar in the retracted position.

Should the main power fail to the group control panel, the supply is automatically switched to the integral standby battery. The curtain remains in the retracted position for up to 2 hours. The curtain will remain fully operational until the battery low voltage cut off facility reads a voltage of 21v, the curtains will then safely descend under the power of gravity to the operational position.

### Motor Control Panel (MCP)

- Run timer (40/80 seconds).
- Controls curtain motor gravity fail safe descent.
- Current controlled curtain ascent with no motor limit switches.
- Option for 2 stage descent functionality with motor brake fitted.
- Separate Individual Override Interface (IOI) for emergency exit on a single curtain.



## Group Control Panel (GCP)

Aerosafe Group Control Panel consists of test key switch, 2 x 12v 7ah back-up batteries, LED status indicators.

Manual override for all curtains connected to a single GCP.



## GCP Backup Batteries

2 x 12v 7ah back-up batteries. Used to hold the curtains up temporarily in the event of a main power failure. Continuously recharged. Typically up to 30 mins operation when no main power. Operational time will depend on number of motors and condition of the battery.

## Group Control Panel (GCP) - Options

- Manual override facility
- Delayed descent/ascent
- Interlinking of multiple GCPs



## Aerosafe Tubular Motor

The Aerosafe Tubular Motor is a permanent magnet DC electrical motor. When the curtains are retracted, the Aerosafe Motor Control Panel (MCP) routes a 24v DC low voltage supply to the motor which keeps it in the retracted position.

When the fire alarm signal is triggered, the low voltage supply to the MCP is removed which in turn deploys the curtains to their fire operational position under the power of gravity.

Based on weight of the curtain, 20W and 40W Nominal Power are selected.

## AEROSAFE CONTROL SYSTEMS OPERATION

### Operation in a Fire Scenario (Fire Alarm Signal Received)

The Aerosafe Group Control Panel (GCP) is powered by a 230v AC, 3 Amp 50 Hz power supply. A pair of normally-closed, volt-free fire alarm contacts supplies the fire alarm signal when commanded by the Building Management System. In its stored position within the head box, the curtains remain retracted and held in place by a low voltage supply (24v DC) to the curtain motors. Upon receipt of a fire alarm signal, the supply to the motor controller is removed, which releases the curtains. Using Aerosafe's Gravity Fail Safe System, the curtains deploy to the operational position at a controlled rate under the force of gravity. No power source is required for curtain deployment.

### Operation in case of Loss of Power (Non-fire Scenario)

In the event of a mains power failure, each GCP is supplied with a battery back-up system providing up to a minimum of 30 minutes of power to the curtain motors. This prevents unintentional deployment of the curtain in a non-emergency situation. Upon exhausting the battery back-up, the curtain will descend safely under gravity.

One GCP has the ability to control a maximum of 5 no.x 20 Watt motor. If the number of motor exceeds 5, GCP's can be linked together. This avoids the need for each GCP to be supplied with its own fire alarm signal. This set up also ensures synchronous descent of multiple curtains. Should a 2 stage descent be required, a brake is added to the motor which is energised by an additional brake cable.

### Optional Features

- Push button emergency override
- Individual curtain override
- 2 stage descent
- Obstruction sensor
- Heat detector
- BMS link facility
- AV facility

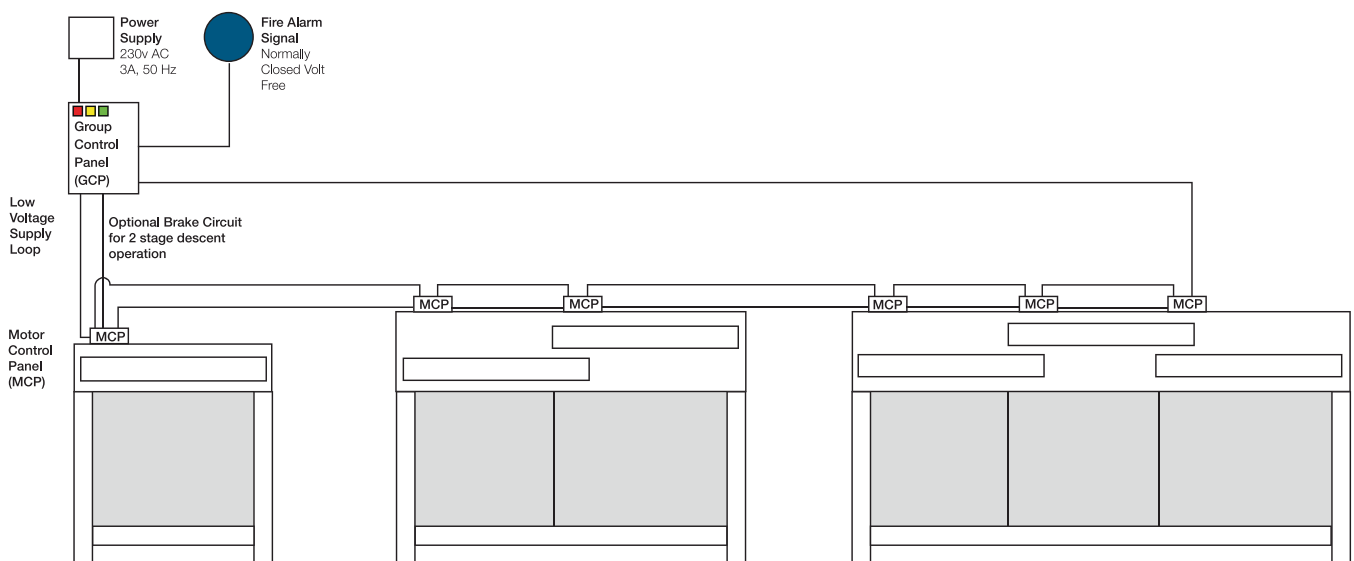

## MAIN FEATURES

- Economical solution which often replace fixed walls, doors or other barriers.
- Easy to install and cost effective with fast lead time.
- Low Maintenance cost & high durability.
- 100% gravity fail safe descent (will operate without power), individual override operations, audio/visual alarms, emergency retract buttons, smart BMS modules, obstruction sensor and other as per the site requirement with best of R&D.
- Design solution: Bespoke designs to fit all requirements and layouts, allow architectural freedom with space usage.
- Width and drops: Aerosafe Smoke Curtains are designed to cover unlimited width.

## SMOKE CURTAINS SPECIFICATION

### Testing Standards

Aerosafe Smoke Curtains are tested in accordance with standards below:

Aerosafe Smoke Curtains	
Model number	HSC-03
Testing standards	BS EN 12101-1
	Fire integrity, smoke leakage & mechanical stability
	Tested in single & multiple barrel orientation
Compliance	Applus-Third party accreditation
Fire resistance E	180 minutes

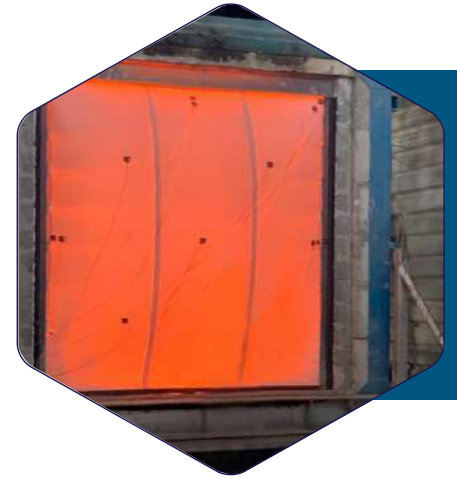

## Applications

A multi-level atrium can be a beautiful and welcoming architectural feature to any building, creating a sense of openness and bringing in natural light. But several stories of open space pose unique challenges when it comes to fire & smoke safety planning. In the event of a fire, an atrium without the proper smoke and fire control technology can facilitate the rapid spread of smoke from one floor to the next, leading to extensive property damage and creating dangerous conditions for building occupants as they evacuate. Automatic Smoke Curtains when deployed once receiving fire alarm help channilizing smoke to exhaust points & create a safer evacuation area.

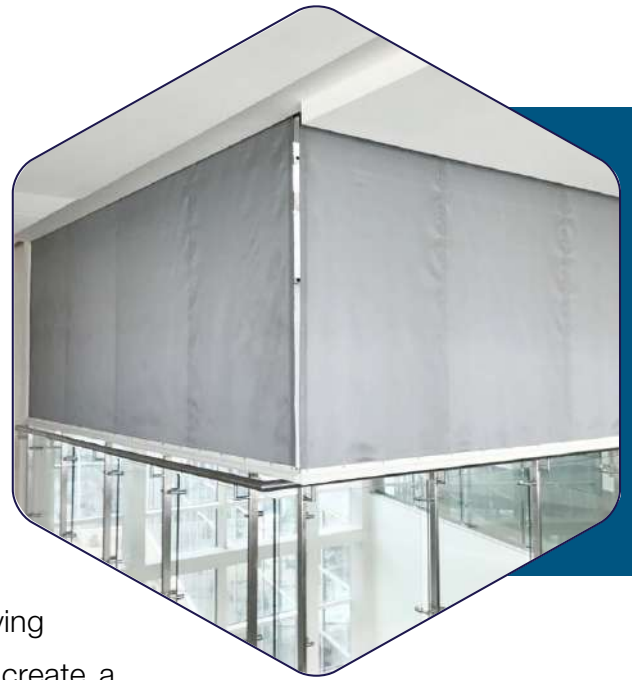

## Smoke Compartmentalization

To prevent spread of smoke from one zone to another smoke curtains are essential element in smoke management strategy in retail shops in malls, hospitals or any building having large open areas.



## Parking & Basement



## DRAFT SMOKE CURTAINS



Aerosafe Draft Curtains are an effective solution designed to provide protection against smoke spread in commercial and industrial structures. Secured to structured steel, draft curtains ensure smoke and hot gases arising from the fire to be channelized to exhaust and extracting point.

## ADVANTAGES

- Customized designs to fit all requirements & layouts
- Lightweight: Reduction in load bearing
- Very easy in installation
- The Static Curtain entail a very low level of maintenance
- Draft Curtains are designed to cover unlimited width

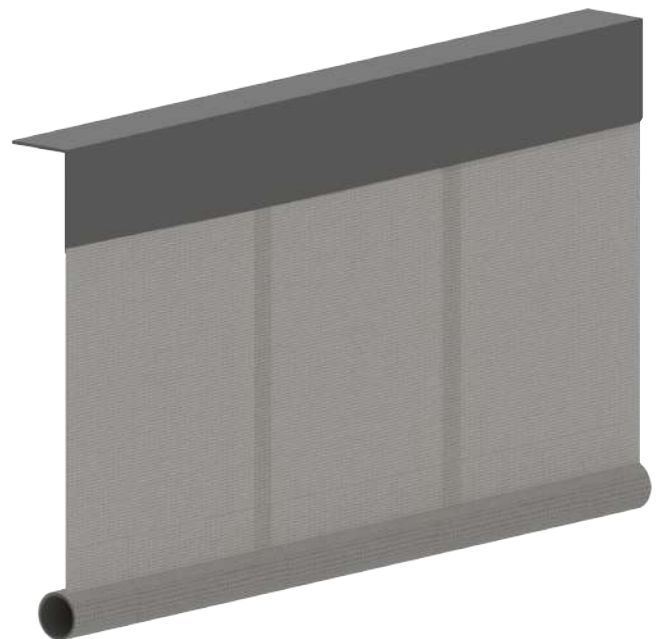

# Global Footprint



 Sales Units       Sales & Manufacturing Units



Al Ghail Industrial Park, Al Ghail - Ras Al Khaimah, United Arab Emirates  
Telephone: +971 7 258 9006 | Email: [enquiry@rhira.com](mailto:enquiry@rhira.com)