

Expansion Device (BUP1000)

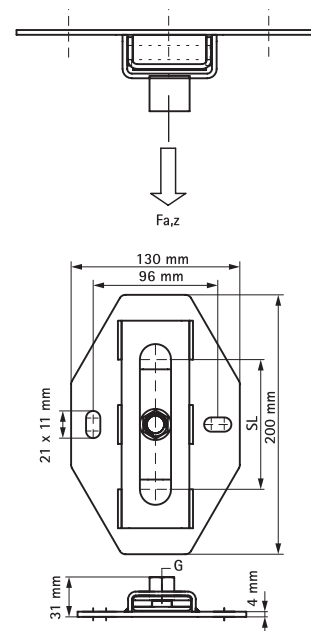

Features and Benefits

- single support for pipe expansion
- secure parts ensure mechanism will not slide out
- suitable for ceiling mounting (suspended) and floor mounting (standing mounted)
- fix directly on the building structure or in combination with rail systems
- very low installation height, useful in small spaces
- material: metal parts made of steel; plastic parts made of POM (polyoxymethylene)
- friction coefficient: $P\mu_o = 0.18$; Sliding friction coefficient $\mu=0.14$
- surface protection:
 - product is part of the BIS UltraProtect®1000 system
 - suitable for in- and outdoor applications
 - stands min. 1,000 hours salt spray test (max. 5% red rust) according to ISO 9227
 - temperature resistance up to +120 °C

Part No.	Model	G	L (mm)	B (mm)	H (mm)	s (mm)	d1 (mm)	k (mm)	SL (max.) (mm)	Fa,z (mm)	Pack 1
666 8 310	Single	M8/M10	130	200	30.5	4.0	21x11	96	100	3.500	5
666 8 312	Single	M10/M12	130	200	32.5	4.0	21x11	96	100	4.800	5
666 8 316	Single	M16	130	200	30.5	4.0	21x11	96	100	4.800	5